

# NKI 35/20 TN

## Dimensions

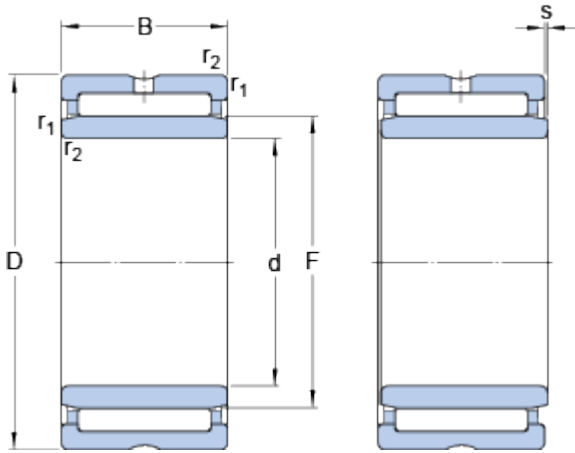

d		35	mm
D		50	mm
B		20	mm
F		40	mm
r <sub>1,2</sub>	min.	0.3	mm
s		0.5	mm

## Abutment dimensions

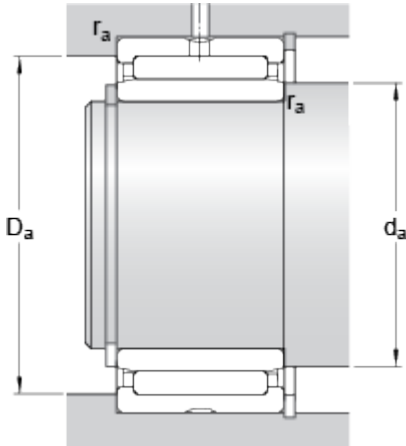

d <sub>a</sub>	min.	37	mm
D <sub>a</sub>	max.	48	mm
r <sub>a</sub>	max.	0.3	mm

## Calculation data

Basic dynamic load rating	C	29.7	kN
Basic static load rating	C <sub>0</sub>	60	kN
Fatigue load limit	P <sub>u</sub>	7.5	kN
Reference speed		10000	r/min
Limiting speed		11000	r/min

## Mass

Mass bearing		0.123	kg
--------------	--	-------	----